

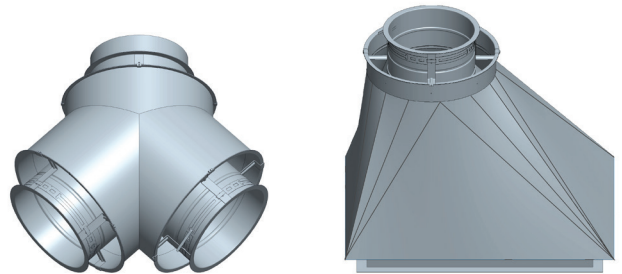

SUBMITTAL RECORD

UL 1978 - Grease Duct Professional Series Kitchen Ventilation

- SCL** Single Wall
- CAX1** 1-inch Air Insulated
- CIX1** 1-inch Insulated (AES WOOL)
- CIX2** 2-inch Insulated (AES WOOL)
- CIX4** 4-inch Insulated (AES WOOL)
- CIX3Z** 3-inch Insulated (AES WOOL)

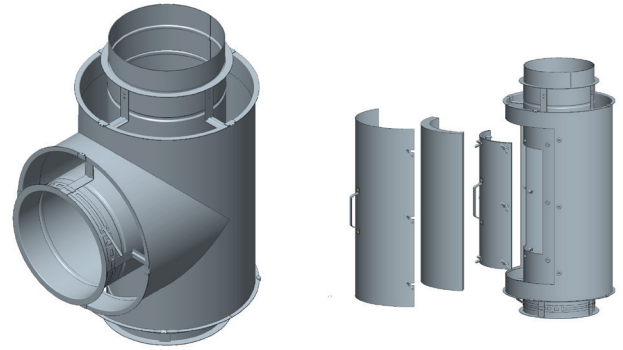

SUBMITTAL RECORD	
PREPARED FOR:	
REFERENCE:	
LOCATION:	
CONTACT:	
TELEPHONE:	FAX:
EMAIL:	
PREPARED BY:	

Listed to standards:
 UL 1978
 UL 2221 - CIX3Z Only
 CAN/ULC S662

Material Selection	
FLUE (INNER WALL)	CASING (OUTER WALL)
304	304
316	441
	GALVALUME

Reference to the Installation Instructions will enable you to obtain a safe, efficient and dependable installation of this vent system. Do not alter or modify the components of this vent system under any circumstances. Any modification or alteration of the vent system or approved accessories, including but not limited to the appliance it is connected to, may void the warranty, listings and approvals of this system and could result in an unsafe and potentially dangerous installation.

Models: SCL, CAX1, CIX1, CIX2, CIX4, CIX3Z

SECTION A – CODE COMPLIANCE

UNDERWRITERS LABORATORIES LISTINGS

Model SCL (single wall) CAX1 (1-inch air), CIX1, CIX2, CIX4, CIX3Z (Double wall, AES Insulation)	
UL 1978 - Grease Duct – All Models	5"- 36" ID
UL 2221 - Fire Resistant Enclosure CIX3Z ONLY	5"- 36" ID
ULC S662 - Grease Duct – All Models	5"- 36" ID

COMPLIES TO THE FOLLOWING:

National Fire Protection Association (NFPA)

- Complies with NFPA 96 – “Standard for Ventilation Control and Fire Protection of Commercial Cooking Operations

International Code Congress (ICC)

- Complies with “International Mechanical Code” and “International Building Code” if applicable to the project or site

International Association of Plumbing and Mechanical Officials (IAPMO)

- Complies with “Uniform Mechanical Code” if applicable to the project or site

UL 1978 Grease Duct Listing:

Security Chimneys Model SCL, CAX1, CIX1, CIX2, CIX4 and CIX3Z are listed for continuous temperatures of 500°F and intermittent temperatures of up to 2000°F, and are ideally suited for use in commercial cooking installations for the removal of smoke and grease laden vapors (Type I or Type II kitchen exhaust hood). Grease duct system size and capacity information may be obtained from the “ASHRAE Handbook – Fundamentals” or from the “Air Pollution Engineering Manual” of the “US Environmental Protection Agency.”

ULC S662 - Grease Duct

These requirements cover factory-built grease ducts and grease duct assemblies that are intended to be installed as alternatives to the grease ducts constructed of all welded 1.37 mm carbon steel or 1.09 mm stainless steel required by ULC-S650, Standard for the Installation and Performance of Ventilation and Fire Suppression Systems for Commercial and Institutional Cooking Equipment. Grease ducts covered by these requirements are intended to be installed in a fire rated enclosure when required by the provincial or territorial regulations or bylaws, or in the absence of those requirements by the National Building Code of Canada. Grease duct assemblies that penetrate fire rated assemblies which do not require the protection of a fire rated enclosure are covered by the requirements contained in CAN/ULCS144, Standard Method of Fire Resistance Test - Grease Duct Assemblies.

UL 2221 Listing:

Security Chimneys Model CIX3Z is classified in accordance with UL 2221 (Tests of Fire Resistant Duct Enclosure Assemblies) as an alternate to a 2-Hr. fire resistant shaft enclosure with a minimum zero clearance to combustibles (sizes 5” to 36” diameters). Model CIX3Z has been evaluated in accordance with the requirements for duct enclosure Condition A.

MIXING PARTS

Model SCL, CAX1, CIX1, CIX2, CIX4 and CIX3Z listed to UL 1978 may be intermixed within a system, assuming proper clearances are maintained for respective components. When penetrating a roof, appropriate roof penetration components must be used.

Do not use Model SCL to penetrate through a wall, floor or roof.

SECTION B – GENERAL INFORMATION

the Outer Band BSE (for Model CAX1, CIX1, CIX2, CIX4 and CIX3Z). See **Figure 1** for the clearance distance.

PART NUMBERS

This submittal identifies major model parts by name and part number.

Material Code Designation:

B = Type 316 Stainless Steel (SS)

C = Type 304 Stainless Steel (SS)

E = Aluminum Zinc Coating (GALVALUME)

K = Type 441 Stainless Steel (SS)

Example:

CAX1 – 36” length with inside diameter of 14” made of SS 316 inner flue and SS 304 outer casing; Code = **CAX1- 14 L36 BC**

CAX1	14	L36	BC
Model	Dia.	Part	Material

CIX2 - 30° elbow with inside diameter 22” made of SS 304 inner flue and Galvalume outer casing; Code = **CIX2- 22 E30 CE**

CIX2	22	E30	CE
Model	Dia.	Part	Material

SCL – wall support for 8” diameter grease duct made of Galvalume; Code = **SCL- 8 WS E**

SCL	8	WS	E
Model	Dia.	Part	Material

Use only factory supplied components. Failure to do so will void the certification and the warranty of the chimney system.

EFFECTIVE LENGTH AND MATERIAL THICKNESS

The effective length is the length of the part when it is assembled.

Effective Length	Thickness for 5” to 36” diameters
L36 = 36-1/8”	inner wall = 0.035”
L24 = 24-1/8”	outer wall = 0.024”
L18 = 17-5/8”	
L12 = 11-5/8”	

CLEARANCE TO COMBUSTIBLE NON - FIRE RATED UL 1978 LISTING APPLICATION

Model CAX1, CIX1, CIX2, CIX4 and CIX3Z can be used for either combustible or non-combustible surroundings. When installed in an open room where enclosure is not required, the chimney may be located at a minimum clearance to adjacent combustible walls in accordance with **Table 1**. The chimney may be located in corners formed by two combustible constructions (walls, floor, ceiling, supports, etc.)

NOTE: The clearance distance with the wall is the distance between the wall and the Inner V-Band (for Model SCL) or

For fire resistive non-combustible enclosure construction, maintain clearance as required for installation access for inspection or per local code. In buildings, more than one story in height and in one-story buildings where the roof-ceiling assembly is required to have a fire resistance rating, the duct must be enclosed in a continuous enclosure from the lowest fire-rated ceiling or floor, through any concealed spaces, to or through the roof to maintain the integrity of the fire separations required by the applicable building code provisions. If the building is less than 4 stories in height, the enclosure shall have a fire resistance rating of not less than 1 hour. If the building is 4 stories or more in height, the enclosure shall have a fire resistance rating not less than 2 hours.

Security Models SCL, CAX1, CIX1, CIX2, CIX4 and CIX3Z chimneys may penetrate a combustible floor, wall, or roof using the appropriate parts and openings sizes.

NOTE: Model CIX3Z is equivalent to a 2-Hr fire rated grease duct enclosure system.

NOTE: Do not completely enclose the chimney with combustible materials.

In the case of a fire rated enclosure made of non-combustible or limited combustible construction, the minimum clearance for Model SCL is 6” or as required by local code.

Model CIX3Z can be used for either combustible or non-combustible surroundings. When installed in an open room where enclosure is not required, the duct may be located at a minimum clearance to adjacent combustible walls

Clearance to Combustible (Unenclosed Surrounding) (from the outer band) Grease Duct UL1978 (500°F / 260°C)					
∅	CAX1	CIX1	CIX2 and CIX4	CIX3Z	SCL
5	4	2	1	0	18
6	5	2	1	0	18
7	5	2	1	0	18
8	5	2	1	0	18
9	5	2	1	0	18
10	5	2	1	0	18
11	5	2	1	0	18
12	6	2	1	0	18
13	6	2	1	0	18
14	6	2	1	0	18
16	6	3	1	0	18
18	7	3	2	0	18
20	7	3	2	0	18
22	7	3	2	0	18
24	8	3	2	0	18
26	8	4	2	0	18
28	8	4	2	0	18
30	9	4	2	0	18
32	9	4	3	0	18
34	9	4	3	0	18
36	10	5	3	0	18

Table 1: Clearance to Combustible

Dimensions are in inches

NOTE: Clearance to non-combustible is 0” for all models / all diameters

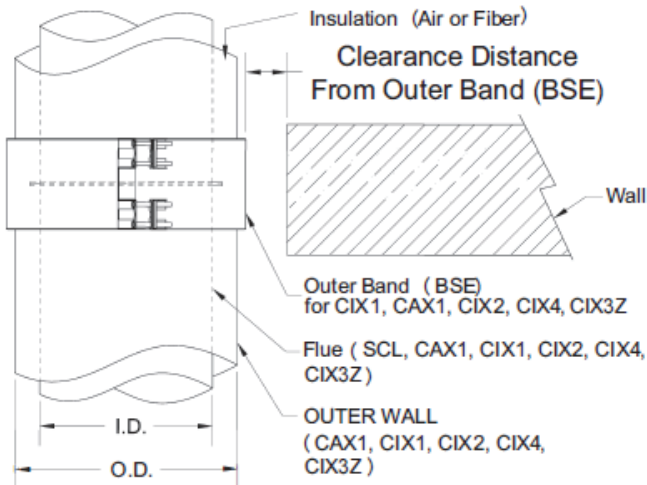

Figure 01: Detail of Clearance to Combustible

WALL THIMBLE (RT)

The part consists of a roof thimble female half and a male roof thimble that slide in each other to adjust wall thickness from 8" to 12". The minimum air space clearance between the outer wall of the duct and the combustible material of the wall, floor or roof must always be respected. The duct must be well supported on both sides of the wall to prevent any load or offset of the duct in the Wall Thimble.

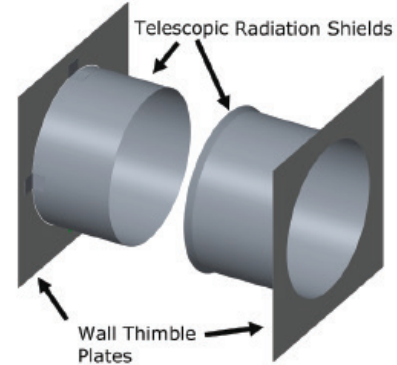

Figure 4: Wall Thimble (WT)

UL 1978 LISTING APPLICATION WALL, FLOOR AND ROOF PENETRATION

A chimney that must penetrate through a wall, floor or roof made of COMBUSTIBLE materials, must use a Wall Thimble (WT) or Roof Thimble (RT). The minimum air space clearance between the outer wall of the duct and the combustible material of the wall, floor or roof must always be respected.

ROOF THIMBLE (RT)

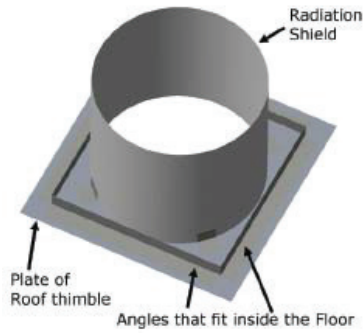

Figure 2: Roof Thimble (RT)

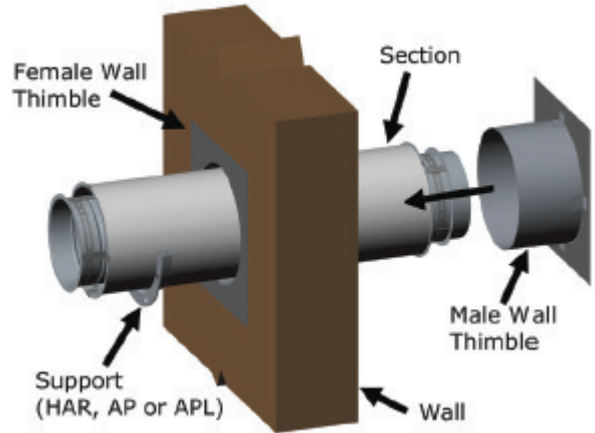

Figure 5: Visualization of Wall Thimble Installed

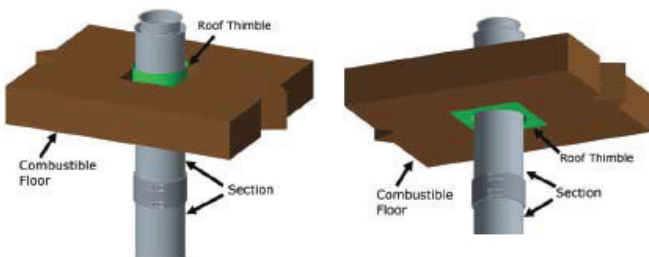

Figure 3: Visualization Roof Thimble Installed

CLEARANCE TO COMBUSTIBLE FIRE RATED

UL 2221

Model CIX3Z is equivalent to a 2 – Hour fire rated grease duct enclosure system.

CIX3Z is “0” inch clearance to combustibles

CLEARANCE TO COMBUSTIBLE (from the outer band - BSE)	
CIX3Z – 5” TO 36”	0”

Table 3: CIX3Z Clearance to Combustible

Model CIX3Z may penetrate a combustible floor, wall or roof using the appropriate parts and opening sizes. Refer to the installation instructions for detailed information.

Whenever the CIX3Z grease duct passes through a fire rated wall or floor, a CIX3Z Ø TPFK must be used to maintain the fire rating.

Fire resistance rating: 2 hours (F & T)

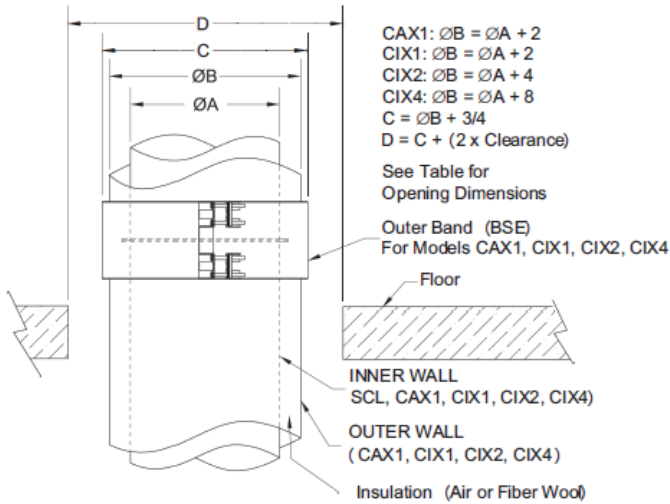

Figure 6: Openings for through Floor / Wall / Roof Models CAX1, CIX1, CIX2, CIX4 made of combustible material Grease Duct – UL1978

Minimum Square OPENING for NON-Fire Rated Floor / Wall / Roof for different Models			
Duct Model	Flue Diameter Ø (in.)	Through Combustible Roof / Floor / Wall (in.)	Through Non-Combustible But NOT-FIRE-RATED Roof / Floor / Wall (in.)
SCL	5 to 36	ID + 37 1/4"	ID + 1 1/4"
CAX1	5	ID + 8 3/4"	ID + 2 3/4"
	6 to 11	ID + 10 3/4"	
	12 to 16	ID + 12 3/4"	
	18 to 22	ID + 14 3/4"	
	24 to 28	ID + 16 3/4"	
	30 to 34	ID + 18 3/4"	
CIX1	36	ID + 20 3/4"	ID + 2 3/4"
	5 to 13	ID + 4 3/4"	
	14 to 24	ID + 6 3/4"	
	26 to 34	ID + 8 3/4"	
CIX2	36	ID + 10 3/4"	ID + 4 3/4"
	5 to 16	ID + 2 3/4"	
	18 to 30	ID + 4 3/4"	
CIX4	32 to 36	ID + 6 3/4"	ID + 8 3/4"
	5 to 16	ID + 2 3/4"	
CIX3Z	18 to 30	ID + 4 3/4"	ID + 6 3/4"
	32 to 36	ID + 6 3/4"	
	5 to 9	ID + 6 3/4"	
	10 to 36		

Table 2: Openings for through Floor / Wall / Roof – NON-Fire-Rated Grease Duct – UL1978

FIRE RATED (2-HR) FLOOR PENETRATION

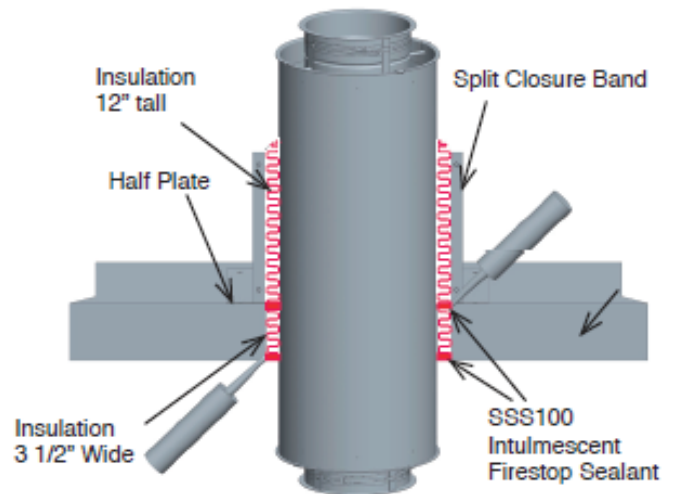

Fig. 7: Through Penetration Firestop fire-rated Floor Penetration

NOTE:

Must use S-TPFS (Spec Seal Triple S Intumescent Firestop Sealant – SSS100). Ordered separately from CIX3ZØTPFK based on duct diameter. Refer to table 4 for tube coverage.

FIRE RATED (2-HR) WALL PENETRATION

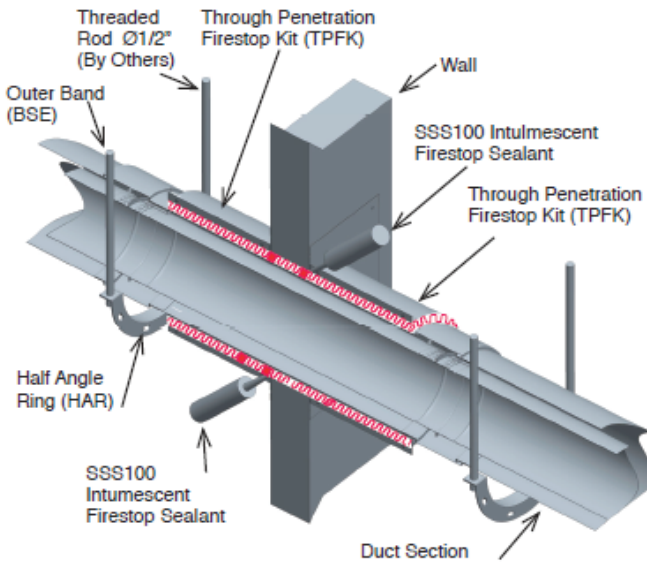

Fig. 8: Through a fire-rated Wall / requires 2 X CIX3ZØTPFK

PROPER STORAGE

All chimney components should be stored in a dry place until installed.
Sealant shall be stored in a location where it will not freeze.

PRODUCT WEIGHT CIX3Z

The average weight of the duct, per foot of length, can be estimated using the following formula:

- SCL:** 0.40 x diameter in inches = lbs per foot
- CAX1:** 0.79 x diameter in inches = lbs per foot
- CIX1:** 0.93 x diameter in inches = lbs per foot
- CIX2:** 1.09 x diameter in inches = lbs per foot
- CIX4:** 1.44 x diameter in inches = lbs per foot
- CIX3Z:** 1.52 x diameter in inches = lbs per foot

SYSTEM SIZING

The Grease Duct system sizing should be done by an experienced person familiar with duct sizing. Not following the equipment manufacturer’s instructions may result in inadequate duct performance and/or a violation of the equipment manufacturer’s installation requirements.

EXTERIOR CORROSION PROTECTION

It is recommended to apply an exterior grade high heat paint to any plate support, full/half angle rings, wall supports/guides, aluminized outer duct wall (Galvalume) corrosion protection against the elements. Rust-Oleum V200 series High Heat Industrial Aerosol is an example for proper protection of these components.

THERMAL EXPANSION CALCULATIONS

Thermal expansion under normal operating temperatures can fatigue welds and joints causing leakage. To calculate the thermal expansion, use the following formula:

[Length (ft.) / 100] X [Temperature Rise Degrees F / 100]

Example: [50' / 100] X 75° / 100 = .375" Expansion

If the computed expansion between the fixed points is greater than .375" Security recommends an adjustable length be installed.

SLOPE FOR GREASE DUCT

For Security factory-built grease ducts listed to UL1978, install at a duct slope not less than 1/16" unit vertical slope in 12 units of horizontal toward the hood or toward the grease reservoir. When Security grease duct listed to UL1978 exceed 75 feet in length, the slope shall not be less than 1/8" unit vertical slope in 12 units horizontal. The minimum slope is a result of tests and/or analysis performed by Underwriters Laboratories, where factory-built grease duct was compared to rectangular field-applied grease duct for performance of flow characteristics. Consult with AHJ for acceptance of this alternate method.

Expected number of tubes of S-TPFS per hole Through a 2 – Hr. Fire Rated Wall or Floor	
Inner Duct Diameter	Number of Tube per hole
5	2 – ¼
6	2 – ½
7	2 – ¾
8	2 – ¾
9	3
10	3 – ¼
11	3 – ¼
12	3 – ½
13	3 – ¾
14	3 – ¾
16	4 – ¼
18	4 – ½
20	5
22	5 – ¼
24	5 – ½
26	6
28	6 – ¼
30	6 – ½
32	7
34	7 – ¼
36	7 – ¾

Table 4: required number of tubes S-TPFS

SECTION C

TYPICAL INSTALLATION for GREASE DUCT

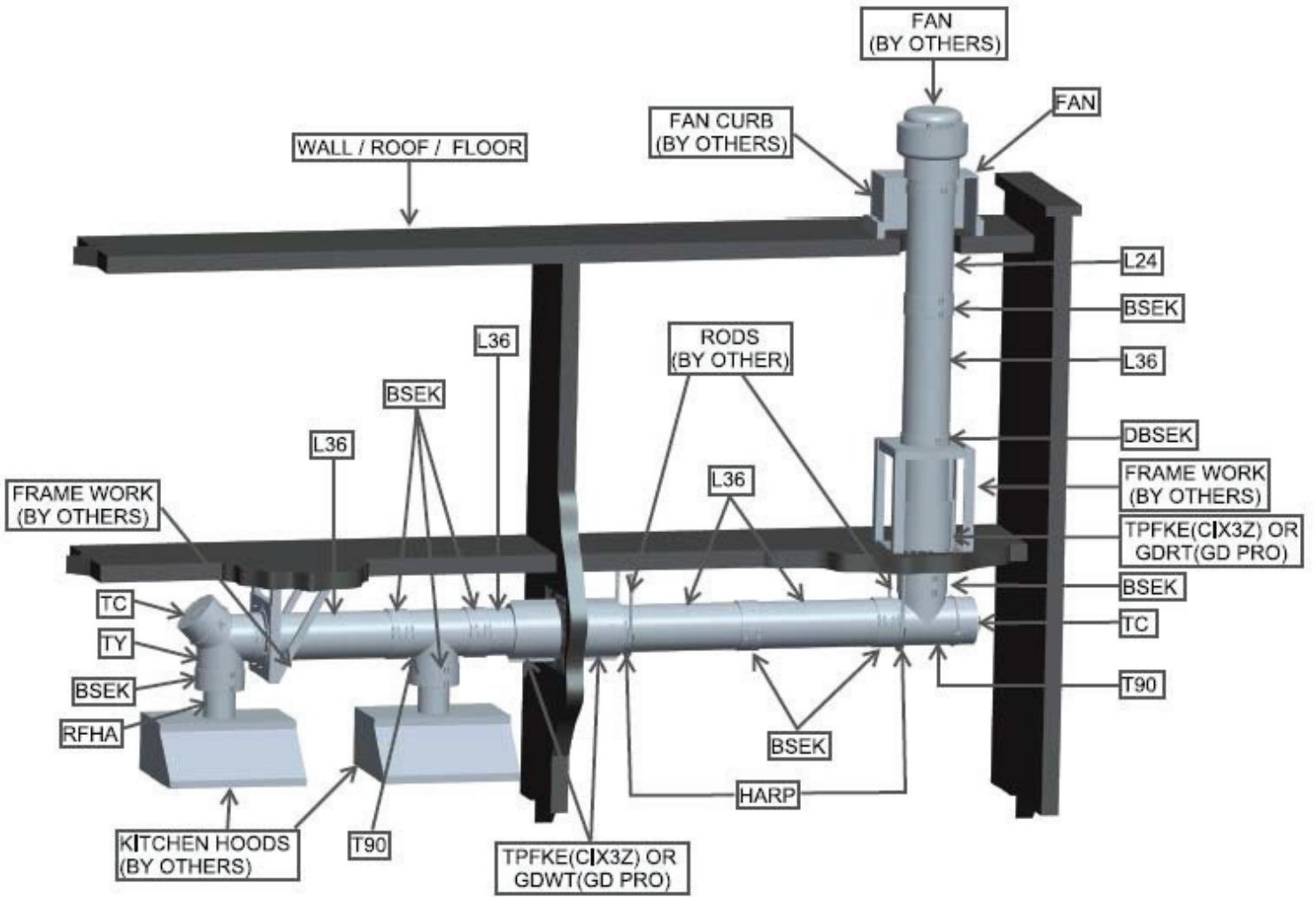

Figure 9: Sample Installation for Grease Duct

SUPPORT METHODS AND HEIGHT LIMITS

- Several support and guiding methods are used to anchor a chimney against upward, downward and angular displacement
- These supports and guides used with thermal expansion devices, prevent bending stresses on the chimney elbows and joints

NOTE:

All the weight of the section must be supported by the inner flue. Never support any chimney duct from the outer wall.

Height Limits for each Type of Support							
Parts	Flue Diameter Ø (in)	Height (ft.)					
		SCL	CAX1	CIX1	CIX2	CIX4	CIX3Z
Anchor Plate (AP)	Ø5 to Ø22	264	133	114	97	73	70
	Ø24 to Ø36	161	82	70	59	45	42
Anchor Plate with Length (APL)	Ø5 to Ø22	281	142	121	103	78	74
	Ø24 to Ø36	172	87	74	63	48	45
Base supported Tee (T90 or T45)	Ø5 to Ø22	102	52	44	37	28	27
	Ø24 to Ø36	63	32	27	23	17	16
Wall Support (WSHD)	Ø5 to Ø22	105	53	45	39	29	28
	Ø24 to Ø36	64	32	28	24	18	17

WARNING: Do not attached any supports to combustible constructions.

Table 5: Support height limits

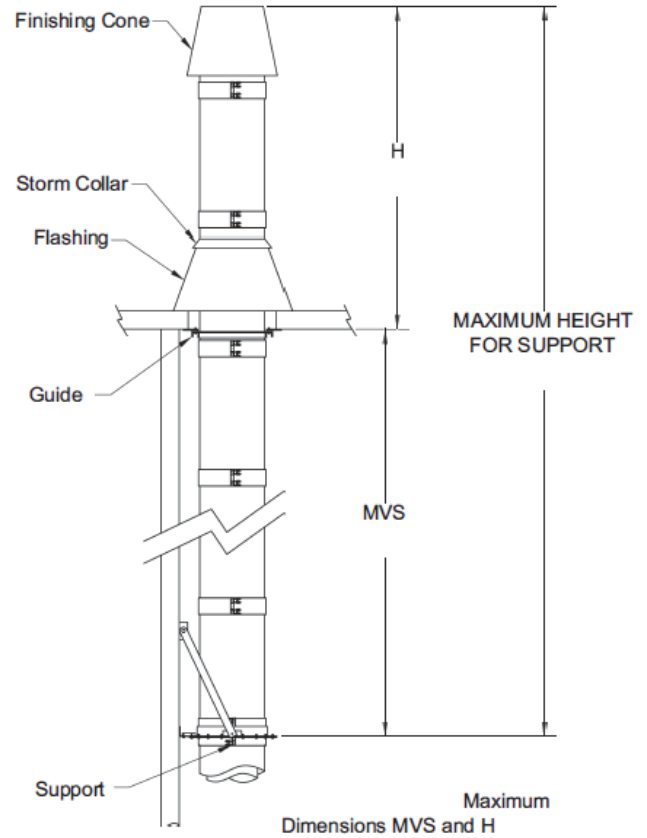

Figure 10: MVS and H limits

Maximum Vertical Spacing between any Guides/Supports and Maximum Freestanding above the Roof										
Model	SCL		CAX1 / CIX1		CIX2		CIX4		CIX3Z	
	Heigth (ft.)		Heigth (ft.)		Heigth (ft.)		Heigth (ft.)		Heigth (ft.)	
Flue Ø (in)	MVS*	H**	MVS*	H**	MVS*	H**	MVS*	H**	MVS*	H**
5	20'	8' 6"	20'	7' 3"	20'	6' 6"	20'	6'	20'	6'
6	20'	9' 6"	20'	8' 3"	20'	7' 6"	20'	6' 9"	20'	6' 9"
7	20'	10'	20'	8' 9"	20'	8' 3"	20'	7'	20'	7'
8	20'	11'	20'	9'	20'	8' 6"	20'	7' 3"	20'	7' 3"
9	20'	11' 6"	20'	9' 3"	20'	8' 9"	20'	7' 6"	20'	7' 6"
10	20'	12'	20'	9' 6"	20'	9'	20'	7' 9"	20'	7' 9"
11	20'	12' 6"	20'	9' 9"	20'	9' 3"	20'	8'	20'	8'
12	20'	13'	20'	10'	20'	9' 6"	20'	8' 3"	20'	8' 3"
13	20'	13' 6"	20'	10' 3"	20'	9' 9"	20'	8' 6"	20'	8' 6"
14	20'	14'	20'	10' 6"	20'	10'	20'	9'	20'	9'
16	20'	14' 6"	20'	11'	20'	10' 6"	20'	9' 6"	20'	9' 6"
18	20'	15'	20'	11' 6"	20'	11'	20'	10'	20'	10'
20	20'	15'	20'	12'	20'	11' 6"	20'	10' 9"	20'	10' 9"
22	20'	15'	20'	12' 3"	20'	11' 9"	20'	11'	20'	11'
24	20'	15'	20'	12' 9"	20'	12' 3"	20'	11' 6"	20'	11' 6"
26	20'	15'	20'	13'	20'	12' 6"	20'	12'	20'	12'
28	20'	15'	20'	13' 6"	20'	13'	20'	12' 3"	20'	12' 3"
30	20'	15'	20'	13' 9"	20'	13' 6"	20'	12' 9"	20'	12' 9"
32	20'	15'	20'	14' 3"	20'	13' 9"	20'	13' 3"	20'	13' 3"
34	20'	15'	20'	14' 6"	20'	14' 3"	20'	13' 6"	20'	13' 6"
36	20'	15'	20'	15'	20'	14' 6"	20'	13' 9"	20'	13' 9"

* MVS = Maximum Vertical Spacing between two guides or support and guide in a vertical position.
 ** H = Maximum Freestanding Heigth above the roof. This limited height is due to wind loads.

Table 6: Support height limits

Maximum Horizontal Spacing between each Guides/Supports							
Product	Flue Diameter Ø (in)	Distance (ft.)					
		SCL	CAX1	CIX1	CIX2	CIX4	CIX3Z
Half Angle Ring (HAR) / Full Angle Ring (FAR) / Anchor Support (AP) / Anchor plate with Length (APL) / Heavy Duty Wall Guide (HDWG)	Ø5 to 12	23	23	19	16	12	12
	Ø14 to 24	19	19	16	14	10	10
	Ø26 to 36	15	15	13	11	8	8

NOTE: The Half Angle Ring (HAR) and Full Angle Ring (FAR) used in horizontal installation must be installed with threaded rods having a minimum of Ø1/2" or with structural steel provided by others.

Table 7: Maximum Horizontal Spacing between Guides / Supports

SECTION D – PIPE & FITTING JOINT ASSEMBLY

The ends of each inner pipe are made of flanges (1/2"). All the joints between sections are a flange-to-flange connection of the inner pipe.

SPECIAL FEATURE

All sections have an unattached "Alignment Sleeve". The alignment sleeve facilitates centering of adjacent sections and provides backing for the sealant applied to the flange keeping the sealant in the intended location. Typically, it is inserted in the downstream end but may be removed. Although not required, it aids in easier assembly, better sealing and adds strength to the section joint.

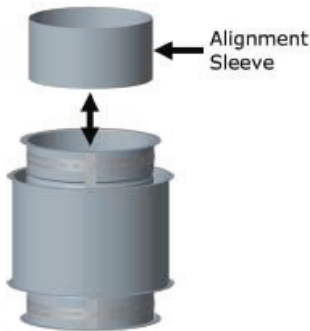

Figure 11: Feature of the Alignment Sleeve

JOINT ASSEMBLY

STEP 1:

Fill the channel of the inner V-band with S-650 sealant supplied by Security and place below the flange of the first section.



Figure 12: Joint Assembly Step 1

STEP 2:

Apply a small continuous bead of S-650 sealant approximately 3/16" wide to one of the flanges to be joined.

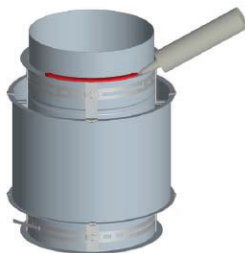

Figure 13: Joint Assembly Step 2

STEP 3:

Join the two flanged ends of the duct section together and rotate slightly to ensure complete coverage of the sealant on flanges.

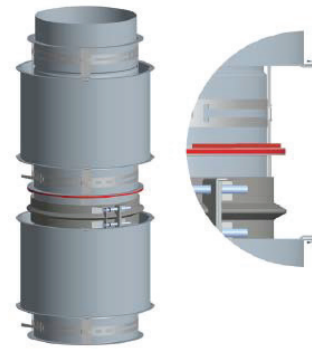

Figure 14: Joint Assembly step 3

STEP 4:

Install the V-band around the flanges making sure the flanges are located within the V-Clamp.

NOTE: do not locate V-band hardware at the bottom side of horizontal ducts

NOTE: light tapping with a hammer all around the band while tightening bolts helps align and pull flanges together.



Figure 15: Joint Assembly step 4

STEP 5:

Install the supplied AES insulation strips between sections to ensure that all gaps are filled. Be sure that insulation is tightly packed and completely fills the void between flue and closure band when assembled.



Figure 16: Joint Assembly step 5

STEP 6:

Secure the Outer Casing with the Outer Band (BSE). Joint installation is complete.



Figure 17: Joint Assembly step 6

NOTE:
Seal the BSE band (top) with S-375 sealant if exposed to weather.

SEALANT USAGE

Part No. S-650
(Permatex® Red High Temp Silicone) is red and is one of our UL approved sealants for temperatures up to (650°F / 344°C). Can also be used for weathering/sealing on outdoor seams and channel bands where necessary.

Part No. S-375
(Nuflex 302 General Purpose) is a low temperature grey silicone (450° / 232°C) only for weathering/sealing on outdoor seams and Outer Band (BSE) where necessary.

Expected number of tubes per joint assembly for S-650 or S-375	
Flue Diameter (in.)	Number of tubes per Joint
5 to 10	1 / 5
11 to 16	1 / 4
18 to 22	1 / 3
24 to 28	1 / 2
30 to 32	2 / 3
34 to 36	3 / 4

Table 8: Tubes per Joint

SECTION E – COMPONENTS

LENGTH (L)

Used as standard duct lengths.

Available in diameters 5” to 36”

L12, L18, L24 and L36



Figure 18: Standard Length

ADJUSTABLE LENGTH (LA) – THERMAL EXPANSION AND ODD LENGTH

Adjust to fit odd lengths and compensate for Thermal Expansion

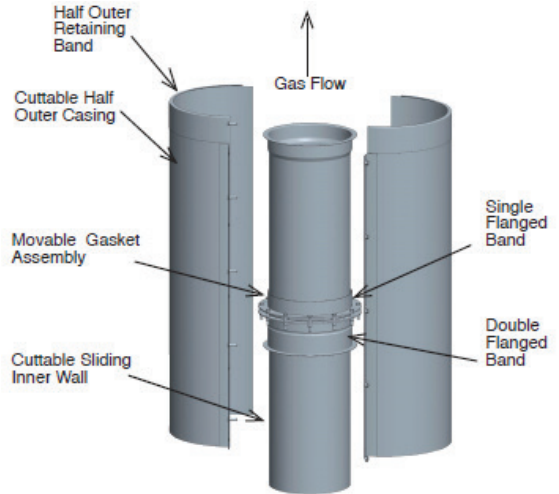

Figure 19: Adjustable Length

VARIABLE LENGTH (LA) – ODD LENGTH - NO THERMAL EXPANSION

Adjust to fit odd lengths only. Primarily used for space between elbow offset when an odd length is required.

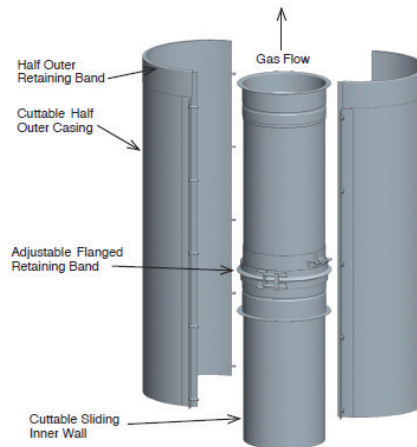

Figure 20: Variable Length

DRAIN LENGTH (DL) – VERTICAL

Used to drain grease or condensate from the inner wall on vertical runs. There is a channel inside the inner wall for directing the flow. A 1" NPT nipple is provided.



Figure 21: Vertical Drain Length

DRAIN LENGTH (HDL) – HORIZONTAL

Used as a horizontal drain in grease duct applications. There is a DAM inside the inner wall for directing the grease to the drain. A 1" NPT nipple is provided.



Figure 22: Horizontal Drain Length

NOZZLE LENGTH (NL)

Used to insert a fire-suppression or wash down nozzle. A 1" NPT nipple is provided.



Figure 23: Nozzle Length

NO TOOL ACCESS DOOR (ADL)

Used for inspection and cleaning. Greaseproof and fire-tight seal. Available in two lengths: 26" and 36" to accommodate spaces.

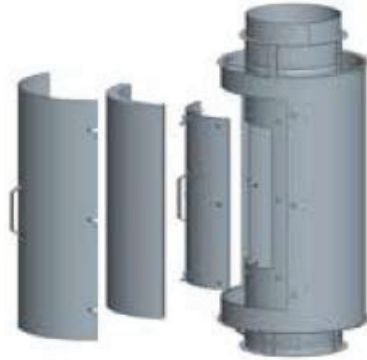

Figure 24: No Tool Access Door

NO TOOL ACCESS TEE CAP (NTTC)

Used to close and seal unused tee ports. Provides easy access for inspection.



Figure 25: No Tool Tee Cap

ELBOWS – E3, E15, E30, E45 and E90

Used to change direction of the duct or to provide an offset. Available in 3°, 15°, 30°, 45° and 90° configurations. Elbows are not designed to take bending loads or thermal expansion.

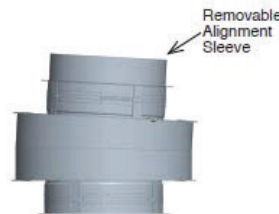

Figure 26: 3° elbow

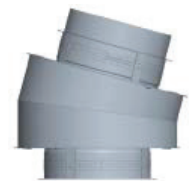

Figure 27: 15° elbow

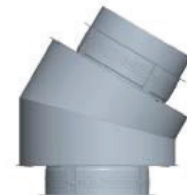

Figure 28: 30° elbow

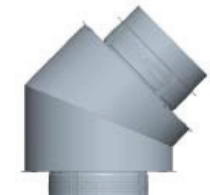

Figure 29: 45° elbow

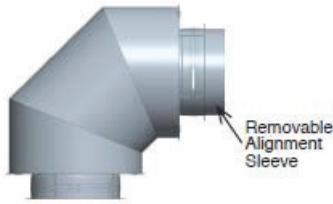

Figure 30: 90° elbow

OFFSETS

Various elbows will create a different configuration for the offset and rise. The chart below (Table 9) provides information for back-to-back elbows



Figure 26A, 27A, 28A, 29A, 30A: Offset of 2 elbows

Minimum (2) Elbow Offsets - CAX1 & CIX1					
Diameter Ø (in.)	3°	15°	30°	45°	90°
5	1/2	2 1/2	5 1/4	8 1/4	18 1/2
6	1/2	2 1/2	5 3/8	8 1/2	19 1/2
7	1/2	2 5/8	5 1/2	8 3/4	20 1/2
8	1/2	2 5/8	5 3/4	9 1/8	21 1/2
9	1/2	2 5/8	5 7/8	9 3/8	22 1/2
10	1/2	2 5/8	6	9 5/8	23 1/2
11	1/2	2 3/4	6 1/8	10	24 1/2
12	1/2	2 3/4	6 1/4	10 1/4	25 1/2
13	1/2	2 3/4	6 3/8	10 1/2	26 1/2
14	1/2	2 3/4	6 1/2	10 7/8	27 1/2
16	1/2	2 7/8	6 3/4	11 3/8	29 1/2
18	1/2	3	7	12	31 1/2
20	1/2	3	7 1/4	12 5/8	33 1/2
22	1/2	3 1/8	7 5/8	13 1/8	35 1/2
24	1/2	3 1/8	7 7/8	13 3/4	37 1/2
26	1/2	3 1/4	8 1/8	14 3/8	39 1/2
28	1/2	3 1/4	8 3/8	14 7/8	41 1/2
30	1/2	3 3/8	8 5/8	15 1/2	43 1/2
32	1/2	3 3/8	8 7/8	16 1/8	45 1/2
34	1/2	3 1/2	9 1/8	16 3/4	47 1/2
36	1/2	3 1/2	9 1/2	17 1/4	49 1/2

Table 9B: Offset chart of elbows

Minimum (2) Elbow Offsets - CIX2					
Diameter Ø (in.)	3°	15°	30°	45°	90°
5	1/2	2 5/8	5 1/2	8 3/4	20 1/2
6	1/2	2 5/8	5 3/4	9 1/8	21 1/2
7	1/2	2 5/8	5 7/8	9 3/8	22 1/2
8	1/2	2 5/8	6	9 5/8	23 1/2
9	1/2	2 3/4	6 1/8	10	24 1/2
10	1/2	2 3/4	6 1/4	10 1/4	25 1/2
11	1/2	2 3/4	6 3/8	10 1/2	26 1/2
12	1/2	2 3/4	6 1/2	10 7/8	27 1/2
13	1/2	2 7/8	6 5/8	11 1/8	28 1/2
14	1/2	2 7/8	6 3/4	11 3/8	29 1/2
16	1/2	3	7	12	31 1/2
18	1/2	3	7 1/4	12 5/8	33 1/2
20	1/2	3 1/8	7 5/8	13 1/8	35 1/2
22	1/2	3 1/8	7 7/8	13 3/4	37 1/2
24	1/2	3 1/4	8 1/8	14 3/8	39 1/2
26	1/2	3 1/4	8 3/8	14 7/8	41 1/2
28	1/2	3 3/8	8 5/8	15 1/2	43 1/2
30	1/2	3 3/8	8 7/8	16 1/8	45 1/2
32	1/2	3 1/2	9 1/8	16 3/4	47 1/2
34	1/2	3 1/2	9 1/2	17 1/4	49 1/2
36	1/2	3 5/8	9 3/4	17 7/8	51 1/2

Table 9C: Offset chart of elbows

Minimum (2) Elbow Offsets - SCL					
Diameter Ø (in.)	3°	15°	30°	45°	90°
5	3/8	2	4 1/8	6 1/4	13 1/4
6	3/8	2	4 1/4	6 5/8	14 1/4
7	3/8	2	4 3/8	6 7/8	15 1/4
8	3/8	2	4 1/2	7 1/8	16 1/4
9	3/8	2 1/8	4 5/8	7 1/2	17 1/4
10	3/8	2 1/8	4 3/4	7 3/4	18 1/4
11	3/8	2 1/8	4 7/8	8	19 1/4
12	3/8	2 1/8	5	8 3/8	20 1/4
13	3/8	2 1/4	5 1/8	8 5/8	21 1/4
14	3/8	2 1/4	5 1/4	8 7/8	22 1/4
16	3/8	2 3/8	5 1/2	9 1/2	24 1/4
18	3/8	2 3/8	5 3/4	10 1/8	26 1/4
20	3/8	2 1/2	6 1/8	10 5/8	28 1/4
22	3/8	2 1/2	6 3/8	11 1/4	30 1/4
24	3/8	2 5/8	6 5/8	11 7/8	32 1/4
26	3/8	2 5/8	6 7/8	12 1/2	34 1/4
28	3/8	2 3/4	7 1/8	13	36 1/4
30	3/8	2 3/4	7 3/8	13 5/8	38 1/4
32	3/8	2 7/8	7 5/8	14 1/8	40 1/4
34	3/8	3	8	14 3/4	42 1/4
36	3/8	3	8 1/4	15 3/8	44 1/4

Table 9A: Offset chart of elbows

TEES - 90° TEES (T90) and 90° TEES with DAM (T90D1 or T90D2)

Used to change direction at 90° breaching. Can be used as an inspection access in horizontal runs. An optional DAM can be ordered in position #1 or #2 for protection against fluids running out.

Available with smaller snout (branch)

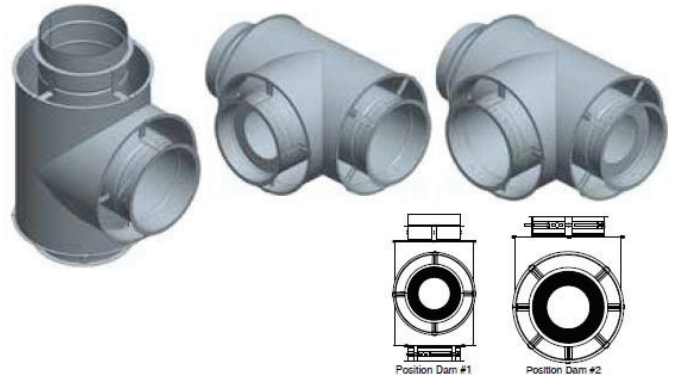

Figure 31: 90° Tee and 90° Tee with DAM

TEES - 90° TEES with NOZZLE (T90N)

Used to change direction at 90° breaching and provides access for installation or inspection of a sprinkler head.

Available with smaller snout (branch)



Figure 32: 90° Tee with NOZZLE

TEES - 45° TEES (T45)

Used to change direction at 45° breaching at low resistance flow.

Available with smaller snout (branch)



Figure 33: 45° Tee

Minimum (2) Elbow Offsets - CIX4					
Diameter Ø (in.)	3°	15°	30°	45°	90°
5	1/2	2 3/4	6 1/8	10	24 1/2
6	1/2	2 3/4	6 1/4	10 1/4	25 1/2
7	1/2	2 3/4	6 3/8	10 1/2	26 1/2
8	1/2	2 3/4	6 1/2	10 7/8	27 1/2
9	1/2	2 7/8	6 5/8	11 1/8	28 1/2
10	1/2	2 7/8	6 3/4	11 3/8	29 1/2
11	1/2	2 7/8	6 7/8	11 3/4	30 1/2
12	1/2	3	7	12	31 1/2
13	1/2	3	7 1/8	12 1/4	32 1/2
14	1/2	3	7 1/4	12 5/8	33 1/2
16	1/2	3 1/8	7 5/8	13 1/8	35 1/2
18	1/2	3 1/8	7 7/8	13 3/4	37 1/2
20	1/2	3 1/4	8 1/8	14 3/8	39 1/2
22	1/2	3 1/4	8 3/8	14 7/8	41 1/2
24	1/2	3 3/8	8 5/8	15 1/2	43 1/2
26	1/2	3 3/8	8 7/8	16 1/8	45 1/2
28	1/2	3 1/2	9 1/8	16 3/4	47 1/2
30	1/2	3 1/2	9 1/2	17 1/4	49 1/2
32	1/2	3 5/8	9 3/4	17 7/8	51 1/2
34	1/2	3 3/4	10	18 1/2	53 1/2
36	1/2	3 3/4	10 1/4	19	55 1/2

Table 9D: Offset chart of elbows

Minimum (2) Elbow Offsets - CIX3Z					
Diameter Ø (in.)	3°	15°	30°	45°	90°
5	1/2	2 5/8	5 3/4	9 3/8	22 1/2
6	1/2	2 5/8	5 7/8	9 5/8	23 1/2
7	1/2	2 3/4	6	9 7/8	24 1/2
8	1/2	2 3/4	6 1/8	10 1/4	25 1/2
9	1/2	2 3/4	6 3/8	10 1/2	26 1/2
10	1/2	2 3/4	6 1/2	10 3/4	27 1/2
11	1/2	2 7/8	6 5/8	11 1/8	28 1/2
12	1/2	2 7/8	6 3/4	11 3/8	29 1/2
13	1/2	2 7/8	6 7/8	11 5/8	30 1/2
14	1/2	2 7/8	7	12	31 1/2
16	1/2	2 1/2	7 1/4	12 1/2	33 1/2
18	1/2	3 1/8	7 1/2	13 1/8	35 1/2
20	1/2	3 1/8	7 3/4	13 3/4	37 1/2
22	1/2	3 1/4	8 1/8	14 1/4	39 1/2
24	1/2	3 1/4	8 3/8	14 7/8	41 1/2
26	1/2	3 3/8	8 5/8	15 1/2	43 1/2
28	1/2	3 3/8	8 7/8	16	45 1/2
30	1/2	3 1/2	9 1/8	16 5/8	47 1/2
32	1/2	3 1/2	9 3/8	17 1/4	49 1/2
34	1/2	3 5/8	9 5/8	17 3/4	51 1/2
36	1/2	3 3/4	9 7/8	18 3/8	53 1/2

Table 9E: Offset chart of elbows

DOUBLE 45° TEE, AVAILABLE with SMALLER SNOOT (TD45)

Used to centrally connect two appliance manifolds to a common duct.

Available with smaller snout (branch)



Figure 34: Double 45° Tee

Y TEE (TY)

Used to provide low-pressure drop joining two appliances. Can be used as a single clean out toward each 90° direction change. Offers the same diameter on all branches but is available with a smaller snout (branch)



Figure 35: Y Tee

LATERAL TEE (BT)

NOTE: The lateral tee is only available up to 24" diameter. For sizes 26" to 36" use a combination of 45° Tee and 45° elbow.

Used to change direction at 90° at a lower resistance flow.



Figure 36: Lateral Tee

TEE CAP (TC)

Used to close, seal or provide access for unused tee ports.



Figure 37: Tee Cap

DRAIN TEE CAP (DTC)

Used to close and seal unused tee ports and to provide a drain port for grease or condensate at the base of a vertical duct. A 1" NPT nipple is provided



Figure 38: Drain Tee Cap

DRAIN BUCKET (DB)

Used at the base of a vertical riser as a drain reservoir and to provide cleanout access. A 1" NPT nipple is provided.



Figure 39: Drain Bucket

TAPERED INCREASER (TIN)

Used when a pipe diameter change is required. Tapered Increases are typically used to provide an increase in duct size, but they may also be used (in the opposite orientation) to reduce the size of the duct. Caution should be exercised in reducing duct sizes due to the resultant increase in flow resistance.

NOTE: typically used in vertical applications to allow grease / condensate flow.



Figure 40: Tapered Increaser

ECCENTRIC TAPERED INCREASER (ETIN)

Used when a pipe diameter change and a flat bottom on horizontal runs is required.



Figure 41: Eccentric Tapered Inserter

ROUND FLANGED HOOD ADAPTER (RFHA)

Used to connect the first duct section to the hood. Can be field welded or supplied to the HOOD manufacturer for installation (by others)



Figure 42: Round Flanged Hood Adapter

SQUARE TO ROUND ADAPTER – CUSTOM PART

Used to connect a round duct to a hood with a square/rectangular collar or to connect to a square duct.

STR's are a custom component and all requests need to go through the Security Design Group at layouts@securitychimneys.com.



Figure 43: Square to Round Adapter

ECCENTRIC SQUARE TO ROUND ADAPTER – CUSTOM PART

Used to connect a round duct to a hood with a square/rectangular collar or to connect to a square duct.

ESTR's are a custom component and all requests need to go through the Security Design Group at layouts@securitychimneys.com.



Figure 44: Eccentric Square to Round Adapter

SECTION F – SUPPORTS

Refer to Table 5 for MAXIMUM HEIGHT / SPACING

HALF ANGLE RING (HAR)

Used for supporting and guiding the duct in horizontal runs. Hardware by others.



Figure 45: Half Angle Ring

FULL ANGLE RING (FAR)

Used for guiding on a vertical run and allows movement for thermal expansion.



Figure 46: Full Angle Ring

LENGTH ANCHOR PLATEE (APL)

Used for supporting the duct in vertical or horizontal runs and to provide a fixed point for thermal expansion consideration. Must not be in contact with combustible material.



Figure 47: Length Anchor Plate

ANCHOR PLATEE (AP)

Used for supporting the duct in vertical or horizontal runs and to provide a fixed point for thermal expansion consideration. Must not be in contact with combustible material.



Figure 48: Anchor Plate

WALL SUPPORT HEAVY DUTY (WSHD)

Used for supporting the vent in vertical runs and to provide a fixed point for thermal expansion consideration. It can maintain a clearance from the outer wall of the vent from 2-1/2" to 10".



Figure 49: Wall Support Heavy Duty

WALL GUIDE HEAVY DUTY (WGHD)

Used for guiding in vertical installation attached to the wall. It can maintain a clearance to the outer wall of the vent from 2-1/2" to 10".



Figure 50: Wall Guide Heavy Duty

FLOOR GUIDE HEAVY DUTY (FGHD)

Used for guiding in vertical installation when passing through a floor or roof. Must not be in contact with combustible material.



Figure 51: Floor Guide Heavy Duty

SECTION G – PENETRATION ROOF / WALL

A chimney that must penetrate through a floor, roof or wall made of COMBUSTIBLE materials, must use a Roof Thimble (RT) or a Wall Thimble (WT). The minimum air space clearance between the outer wall of the chimney and the combustible material of the roof / floor / wall listed in the **Table 1** must always be respected when using a Roof Thimble (RT) or a Wall Thimble (WT).

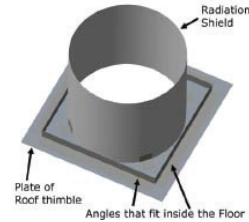

Figure 52: Roof Thimble

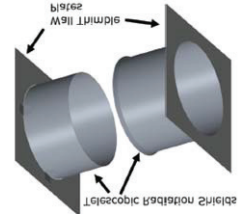

Figure 53: Wall Thimble

2-HOUR FIRESTOP THROUGH PENETRATION FIRESTOP KIT (TPFK) CIX3Z ONLY

Used to maintain the fire resistance rating of a floor or a wall when the grease duct CIX3Z is penetrating a 2-hour fire-rated floor or wall (UL System No. C-AJ-7160). One kit required for a floor penetration and two kits required for a wall penetration. Diameter of penetration is outer casing + 2" (\varnothing ID + 8"). Must use the firestop caulking S-TPFS (Spec Seal Triple S Intumescent Firestop Sealant – SSS100). Refer to Table 2

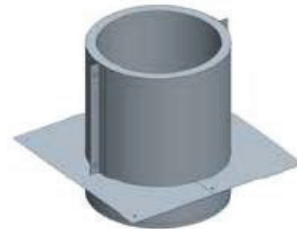

Figure 54: Through Penetration Firestop

SECTION H – FLASHING / STORM COLLAR

FLASHING (F)

Used in conjunction with storm collar (included) for weatherization at the roof.

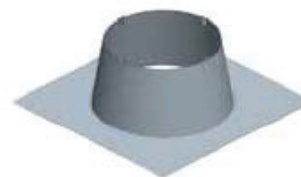

Figure 55: Flashing

ADJUSTABLE FLASHING (F30)

Used in conjunction with storm collar (included) for weatherization at the roof 5° to 30° pitch.

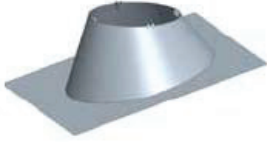

Figure 56: Adjustable Flashing

STORM COLLAR (SC)

Used above the Flashing or Adjustable Flashing for complete weatherization above the roof. To be sealed with outer joint sealant (ordered separately).



Figure 57: Storm Collar

SECTION I – TERMINATIONS

FAN ADAPTER (FAN)

Used to connect to the inlet of an UPBLAST fan.

NOTE: Plate size (A B) must be specified. Hardware for connection is not included and is by others.

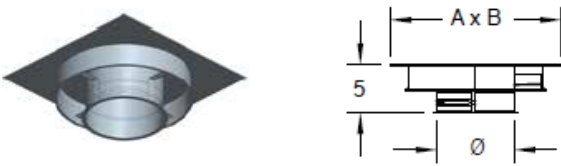

Figure 58: Fan Adapter

CONE RAIN CAP (CRC) / CONE RAIN CAP with BIRDSCREEN (CRCB)

Used to provide the greatest degree of rain protection for a standard vertical termination without fan.



Figure 59: Cone Rain Cap

MITER CUT (MC)

Used for horizontal exhaust with INLINE fan.



Figure 60: Miter Cut

This Security Chimneys Limited Lifetime Warranty warrants your Factory-Built Grease Duct (Product) in a grease duct application to be free from defects in material and workmanship at the time of manufacture when properly connected to and included as a part of a code compliant commercial kitchen ventilation system for cooking appliances. This Limited Lifetime Warranty includes all components and fittings. After installation, if covered components manufactured by Security Chimneys are found to be defective in materials or workmanship during the Limited Lifetime Warranty period and while the Product remains at the site of the original installation, Security Chimneys will, replace the covered components. Security Chimneys reserves the right to replace covered components with an equivalent product and the replacement must be carried out in accordance with Security Chimneys recommendations. If replacement is not commercially practical, Security Chimneys will, at its option, refund the purchase price or wholesale price of the Security Chimneys Product, whichever is applicable. Labor or freight costs to remove or replace Security Chimneys components is not included. THERE ARE EXCLUSIONS AND LIMITATIONS to the Limited Lifetime Warranty as described herein.

COVERAGE COMMENCEMENT DATE

Warranty coverage begins on the date of shipment from Security Chimneys.

EXCLUSIONS AND LIMITATIONS

This Limited Lifetime Warranty applies only if the Product is installed in the United States or Canada and only if used for the application for which it was designed and intended. The Product must be installed and maintained in accordance with the design, installation and maintenance instructions for the Product and in compliance with all applicable installation and building codes and high quality, industry accepted trade practices.

This warranty is non-transferable and extends to the original owner only. The Product must be purchased through a Security Chimneys Agent/Representative and proof of purchase must be provided.

Components and fittings (excludes labor) –

Year 1-10 – Replacement of all components and fittings.

Year 11-15 – Replacement at 75% off of the prevailing list price in effect at the time of replacement (25% of the retail list price paid by the consumer).

Year 16 + – Replacement at 50% off of the prevailing list price in effect at the time of replacement (50% of the retail list price paid by the consumer).

Security Chimneys will not be responsible for: (a) damages caused by normal wear and tear, corrosion from salt air, accident, riot, fire, flood, high wind or acts of God; (b) damages caused by abuse, negligence, misuse, or unauthorized alteration or repair of the Product affecting its stability or performance. (c) damage resulting from failure to reasonably clean, care for or maintain products in accordance with the printed design, installation and maintenance instructions for the Product; (d) damages caused by failing to provide proper maintenance and service in accordance with the design, installation and maintenance instructions for the Product, including damage to the finish of the Product caused by the use of improper solvents/chemicals or improper cleaning methods; (e) damages, repairs or inefficiency resulting from faulty installation or application of the Product; (e) replacement of system sealants as a result of improper installation or a system grease fire.

This Limited Lifetime Warranty covers only parts as provided herein. Security Chimneys's entire liability is limited to the purchase price of this Product. In no case shall Security Chimneys be responsible for materials, components or construction which are not manufactured or supplied by Security Chimneys or for the labor necessary to install, repair or remove such materials, components or construction. All replacement or repair components will be shipped F.O.B. from the Security Chimneys manufacturing facility.

LIMITATION ON LIABILITY

It is expressly agreed and understood that the sole obligation of Security Chimneys and the purchaser's exclusive remedy under this warranty, under any other warranty, expressed or implied, or in contract, tort or otherwise, shall be limited to replacement, repair, or refund, as specified herein.

In no event shall Security Chimneys be liable for any incidental or consequential damages caused by defects in the Product, whether such damage occurs or is discovered before or after replacement or repair, and whether such damage is caused by Security Chimneys negligence.

Security Chimneys makes no expressed warranties except as stated in this Limited Lifetime Warranty. The duration of any implied warranty is limited to the duration of this expressed warranty.

No one is authorized to change this Limited Lifetime Warranty or to create for Security Chimneys any other obligation or liability in connection with the Product. Some states and provinces do not allow the exclusion or limitation of incidental or consequential damages, so the above limitations or exclusions may not apply to you. The provisions of this Limited Lifetime Warranty are in addition to and not a modification of or subtraction from any statutory warranties and other rights and remedies provided by law.

INVESTIGATION OF CLAIMS AGAINST WARRANTY

Security Chimneys reserves the right to investigate any and all claims against this Limited Lifetime Warranty and to decide, in its sole discretion, upon the method of settlement.

Security Chimneys shall in no event be responsible for any warranty work done by a contractor that is not approved without first obtaining Security Chimneys's prior written consent.

HOW TO REGISTER A CLAIM AGAINST WARRANTY

In order for any claim under this warranty to be valid, you must contact the Security Chimneys Agent/Representative from which you purchased the Product. If you cannot contact the Agent/Representative, then you must notify Security Chimneys in writing. Security Chimneys must be notified of the claimed defect in writing within 90 days of the date of failure. Notices should be directed to the Security Chimneys Warranty Department.

WARRANTY

This product has a 15 year limited warranty. Please read the warranty to be familiar with its coverage.

Retain this manual. File it with your other documents for future reference.

PRODUCT REFERENCE INFORMATION

Please contact Security Chimneys International for the phone number of your nearest Security Chimneys International dealer who will answer your questions or address your concerns.

Normally, all parts should be ordered through your Security Chimneys International distributor or dealer. Parts will be shipped at prevailing prices at time of order.

When ordering repair parts, always give the following information:

1. The model number of the vent system.
2. The part number.
3. The description of the part.
4. The quantity required.
5. The installation date of the chimney system.

If you encounter any problems or have any questions concerning the installation or application of this system, please contact your dealer.



2125 MONTEREY ST. • LAVAL, QC., CANADA • H7L 3T6
800-667-3387; www.securitychimneys.com

Security Chimneys International Limited reserves the right to make changes at any time, without notice, in design, materials, specifications, prices.
Consult your local distributor for chimney system code information.